

GreenTek®

Trusted by the best in the game

MULTI-SAREL

OPERATOR'S MANUAL



INTRODUCTION

Congratulations on purchasing the GreenTek Multi-Sarel. This British designed and manufactured product has been engineered to give years of use, provided it is used and maintained correctly.

As with all tractor mounted equipment, it is essential that all operators read and follow these instructions in order to use the Multi-Sarel safely without endangering themselves or other persons.

MACHINERY MARKINGS

Your machine carries a serial number plate. Please quote your serial number when ordering spare parts.

APPLICATION

The Multi-Sarel is a unique dual-purpose roller which can be used either with the wing rollers folded out for spiking large areas such as sports fields and golf course fairways, or with all the rollers mounted together on the centre frame for more intensive spiking.

This equipment is designed solely for surface aeration of sports and amenity turf. Use in any other way is contrary to the intended use.

The manufacturer accepts no liability for damage or injury resulting from misuse. Compliance with the instructions in this manual is essential for safe operation.

SAFETY WARNINGS

General

This turf maintenance system is designed to be operated by a tractor of not less than 35HP with a hydraulic lifting capacity of at least 600kg. Front weights may also be necessary when operating this machine.

All operators must also read and follow all instructions in the operators' handbook supplied with the tractor.

Before Starting the Tractor Engine

Check that the brakes are applied, drives are in neutral, guards are in position and intact and bystanders are clear of the machine. Do not run the engine in a building without adequate ventilation.

MULTI-SAREL

Operating the Machine

Always wear suitable protective clothing (eg, gloves and steel toecap footwear), when operating sharp or heavy machinery.

Before moving the machine, check to ensure that all the parts are in good working order, paying particular attention to tyres, steering, brakes and lights. Double check that the attachment is fitted securely to the tractor 3 point linkage.

Always observe the Highway Code both on and off the roads. Keep alert and aware at all times. Remember that some people are deaf or blind; that children and animals can be unpredictable. Keep travelling speeds low enough for an emergency stop to be effective and safe at all times.

Take special care when reversing and ensure that the area behind is clear of obstructions. Remove or avoid obstructions in the working area.

Leaving the Driving Seat

Park the tractor on level ground. Before leaving the driving seat, stop the engine and make sure all moving parts are stationary. Apply brakes and disengage all drives. Remove the ignition key.

Slopes

Take extra care when working on slopes.

Local undulations and sinkage will change the general slope. Avoid ground conditions which will cause the tractor to slide or roll over. Apply brakes before disengaging tractor gears. Keep the tractor completely under control when disengaging traction clutch. Remember that the extra weight of the attachment will affect the balance and stability of your tractor.

Inspect all components and hydraulic hoses for damage before using. Do not use with faulty components.

Switch off tractor engine, operate spools to release hydraulic pressure before connecting or disconnecting hoses. Never work on machine with tractor running or unreleased pressure in the hydraulic system.

Never operate the machine near bystanders.

WARNING: Rollers fold out to 5.4m.

REMEMBER:

IT IS THE OPERATORS RESPONSIBILITY TO ALWAYS ENSURE THAT THIS MACHINE IS IN SAFE WORKING ORDER BEFORE USE AND THAT CONDITIONS ARE SUITABLE FOR IT TO BE USED WITHOUT ENDANGERING THE OPERATOR OR OTHERS.

GreenTek[®]

Trusted by the best in the game

Tel: +44 (0)113 267 7000
Email: info@greentek.uk.com
Web: www.greentek.uk.com

WARNING DECALS

The following decals are affixed to your Greens Groomer which must be obeyed at all times. Replacement decals are available free of charge from the manufacturers.

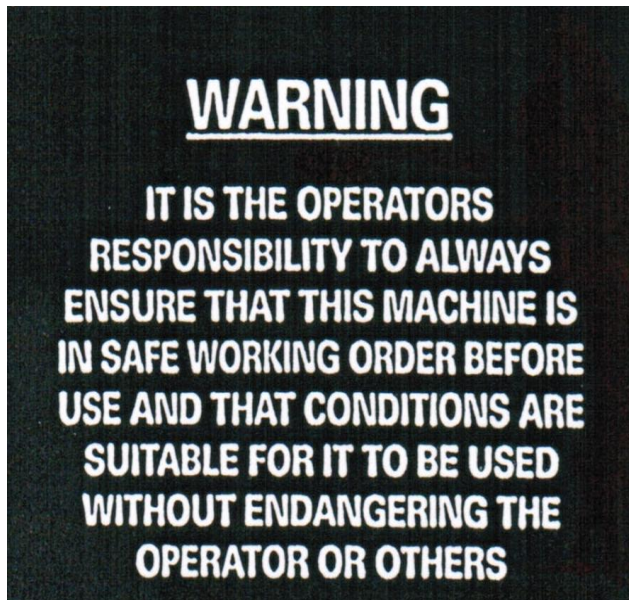
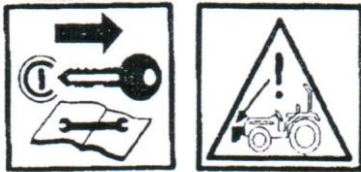
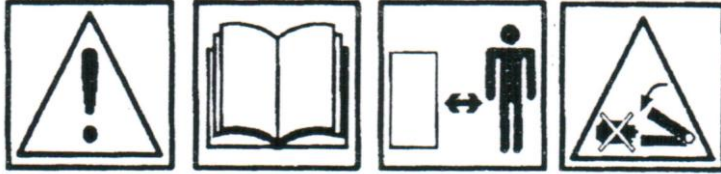

OPERATING INSTRUCTIONS

Fitting to Tractor

The Multi-Sarel is intended to be used with 4WD compact tractors of at least 35hp. It is essential that the operators follow all safety procedures set out in the tractors operators' manual.

The Multi-Sarel simply attaches to any Category 1 3-point linkage by means of conventional top and bottom link pins. Tighten anti-sway chains and lock the 3 stand legs into their raised position.

Ensure that the linkage is adjusted correctly so that the Multi-Sarel centre frame hangs level from side to side. Adjust the top link so that the centre post to which it attaches is vertical when in operation.

Connect the hydraulic pipes to the tractor (1 double-acting spool valve is required).

Operate the hydraulic spool gently and the 2 wing arms will fold out. Hold the valve open until the hydraulic rams are fully extended. Operate the valve in the other direction to fold in the wings for intensive spiking or transport.

Attach the counterbalance spring kit to the top link as shown below and adjust. This is to even out the weight distribution between the heavier centre frame and the wings to ensure a consistent working depth. Do not use the slotted position to mount the top link, this is for different machine configurations.



To connect the counterbalance spring, the tractor lift arms should be fully raised. In this position there will be no tension on the spring, which enables it to be easily connected by means of the D shackles, as shown above.

To adjust the spring tension, the stand legs should be locked up, and the tractor linkage fully lowered so that all rollers rest on the ground. Then by altering the number of chain links used, and tightening or loosening the turnbuckle, the tension on the spring can be adjusted until the centre frame has the same down pressure as the wing frames.

USING THE MULTI-SAREL

DO NOT REVERSE OR TURN UNLESS THE MULTI -SAREL IS LIFTED CLEAR OF THE GROUND. ONLY ROLL IN STRAIGHT LINES.

WARNING: Do not operate or fold out rollers without checking for obstacles. Keep bystanders at least 5m away.

OPTIONAL BRUSH KIT

Adjust the brushes by loosening the clamp bolts and set them to so they gently touch the surface when the spikes are fully into the ground, then tighten clamp bolt. From time to time rotate brushes through 180° to compensate for wear.

UNCOUPLING THE MULTI-SAREL

To uncouple the Multi-Sarel from the tractor, first lift the 3-point linkage, then fully lower and securely lock down all three drop legs. Then lower the mainframe and uncouple from the tractor.

NEVER UNCOUPLE THE MULTI-SAREL FROM THE TRACTOR UNLESS ALL THREE DROP LEGS ARE SECURELY LOCKED DOWN.

MAINTENANCE

Pressure wash all debris off the rollers (and optional brushes if fitted) after each time of use. Apply a small amount of grease to the sloping ramp. Grease all nipples weekly.

Lock the 3 stand legs in their lower position before uncoupling the Multi- Sarel from the tractor, and always store in this position. Check condition of hydraulic hoses and couplings regularly, and replace any damaged components.

MULTI-SAREL

PARTS LISTING FOR HYDRAULIC MULTI ROLLER

Item	Description	Qty	Part No
1	MAIN FRAME	1	HMR 001
2	WING ARM	2	HMR 002
3	WING FRAME	2	HMR 003
4	RAM LINK YOKE	2	HMR 008
5	TOP LINK PIN	1	HMR 005c
6	LYNCH PIN	3	HMR 006c
7	LOWER LINK PIN	2	HMR 007c
8	SUPPORT LEG PIN	3	HMR 004c
9	R-clip	5	HMR 010c
10	SUPPORT LEG	3	HMR 009c
11	BEARING MOUNTING BOLT	12	HMR 011
12	WING ARM PIVOT PIN	2	HMR 012c
13	HYD RAM MOUNT PIN	2	HMR 013c
14	UPPER ANCHOR PIN	2	HMR 014c
15	BUSHING	6	HMR 015c
16	THRUST WASHER	2	HMR 016c
17	RUBBER CUSHION ASSY	4	HMR 017
18	SHIM WASHER	4	HMR 018
19	TENSION PIN	2	HMR 019c
20	PIN RETAINING BOLT	2	HMR 020c
21	SET SCREW HEX HEAD	2	HMR 021c
22	ANTI SWAY BLOCK	2	HMR 022c
23	WING FRAME MOUNT BLT	8	HMR 023c
24	HYD RAM	2	HMR 024c
25	HYD PIPE	1	HMR 025c
26	HYD PIPE	1	HMR 026c
27	HYD PIPE	1	HMR 027c
28	HYD PIPE	1	HMR 028c
29	ADAPTOR	2	HMR 029c
30	TEE ADAPTOR	2	HMR 030c

GreenTek[®]

Trusted by the best in the game

Tel: +44 (0)113 267 7000
Email: info@greentek.uk.com
Web: www.greentek.uk.com

MULTI-SAREL

PARTS LISTING FOR HYDRAULIC MULTI ROLLER

Item	Description	Qty	Part No
31	ADAPTOR	2	HMR 031c
32	Q/R COUPLING	2	HMR 032c
33	ADAPTOR	2	HMR 033c
34	PIPE CLAMP ASSY	7	HMR 034c
35	ROLLER (LONG)	1	HMR 035
36	SCRAPER (LONG)	1	HMR 036
37	ROLLER (SHORT)	2	HMR 037
38	SCRAPER (SHORT)	2	HMR 038
39	SHORT ROLLER MOUNT BKT	4	HMR 039
40	LONG ROLLER MOUNT BKT	2	HMR 040
41	SUPPORT BRG	6	HMR 041
42	ROLLER BKT MOUNT bolt assy	16	HMR 042
43			
44			
45			
46	Hose kit inc items 25-34	1	

To order spare parts please email spares@greentek.uk.com or call +44 (0)113 267 7000.

GreenTek[®]

Trusted by the best in the game

Tel: +44 (0)113 267 7000
Email: info@greentek.uk.com
Web: www.greentek.uk.com

MULTI-SAREL

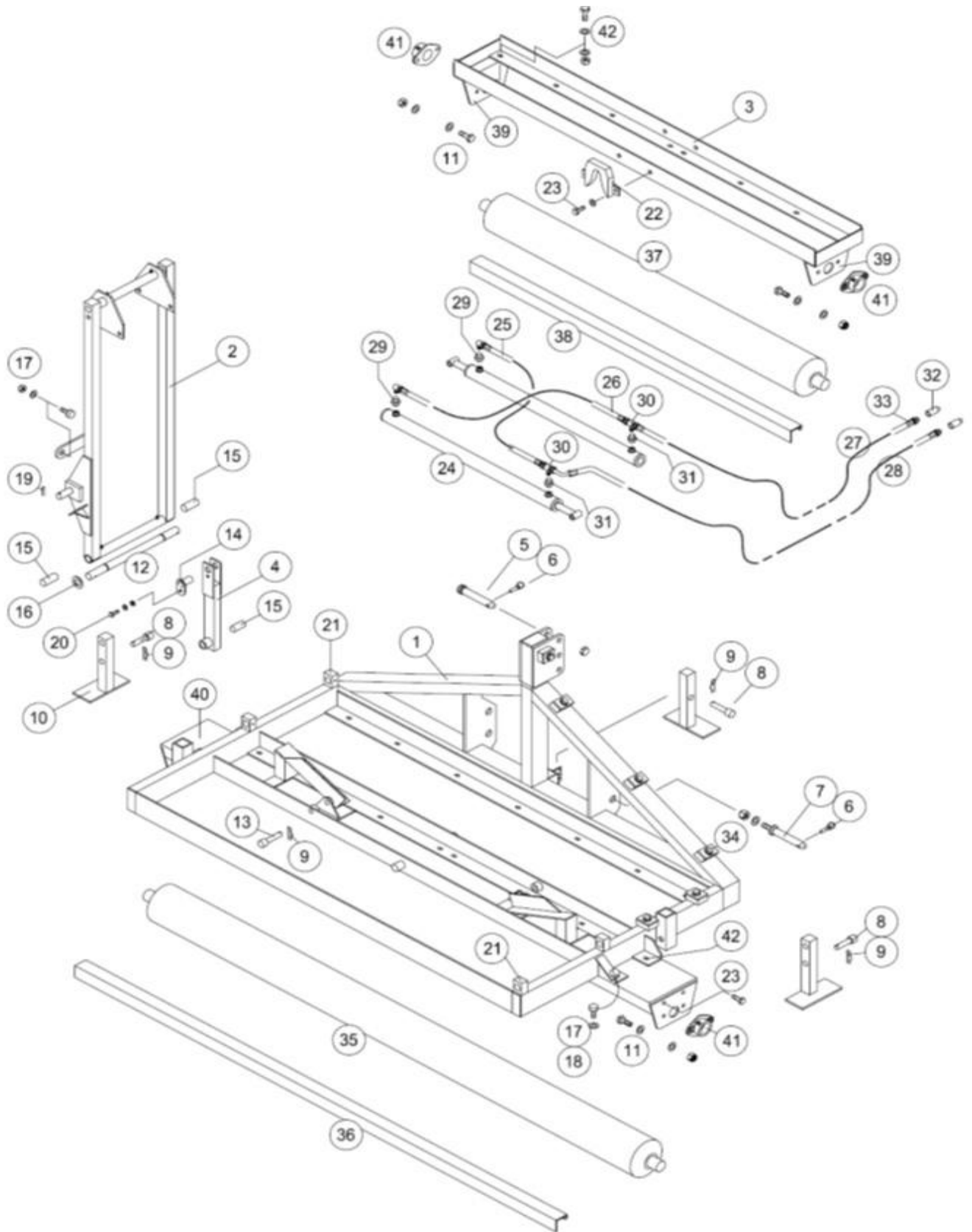

GreenTek[®]

Trusted by the best in the game

Tel: +44 (0)113 267 7000
Email: info@greentek.uk.com
Web: www.greentek.uk.com

GUARANTEE

We guarantee that should any defect in materials or workmanship occur within 24 months of purchase, we will repair or, at our option, replace the defective parts free of charge provided that the fault is reported to us immediately it becomes apparent.

Damage caused by normal wear, misuse or in transit is not covered by this guarantee.

Certificate of CE Conformity

Date: 25 February 2014
Machine Model: Multi-Sarel
Description: Tractor Mounted Aerator
Serial Number:

I hereby certify that the machine detailed hereon conforms to European Directives 89/392EEC as amended 91/368EEC – 93/44EEC – 93/68EEC.

Signed: 
.....

(Quality Manager)

CONTACT US

For further information, support or advice please contact:

info@greentek.uk.com

+44 (0)113 267 7000